

## FEATURES & BENEFITS

- All digital processing
- High resolution / precision [6  $\mu$ rad]
- 32 bit digital output covering  $\pm 2000$  fringes
- Adjustable modulation frequency
- Selectable high pass filter for digital and analog outputs
- Selectable data averaging
- Enable/disable servos
- Single or Multi-channel configurations
- Built-in optical receiver
- Polarization Diversity Receiver option
- USB 2.0 interface
- Quick set-up and on-the-fly parameter changes
- PhaseView software for system set-up, control, monitoring and data capture.

The **OPTIPHASE® OPD-4000** is the world's leading instrument for high-precision interferometric measurement applications. Developed by experts in the use of fiber based interferometry, the OPD-4000 delivers previously unattained levels of cost-effective performance and ease-of-use for a wide variety of applications.

The OPD-4000 is a simple yet powerful instrument for measuring interferometric phase. The unique and patented digital process provides for simultaneous low noise and high dynamic range operation. For anyone designing, developing or using a fiber-based interferometer, there is no better way to get faster, easier and more cost effective measurement results.

The OPD-4000 is a DSP based large-angle optical phase demodulator. It performs demodulation of interferometers that can accommodate Phase Generated Carrier [PGC] modulation [see chart below]. Through precise monitoring of the received optical signal, the OPD-4000 automatically determines the proper parameters for gain-optimizing the receiver signal, stabilizing modulation depth at  $\pi$  radians and sampling phase for accurate quadrature

signal extraction. Optical phase is determined through inverse trigonometric functions and dynamic range is enhanced via fringe counting. The measured optical phase is a 32 bit word updated once per modulation cycle. Output formats are digital [USB 2.0] and 20 bit analog. A Polarization Diversity Receiver is available for those needing to address polarization fading. The OPD-4000 ships with PhaseView software, a powerful MS Windows based user interface for easy set-up and data transfer.

Whether you are conducting research and development, designing photonic components or sensor systems, the OPD-4000 will serve as an indispensable tool in all your applications. Outside the R&D arena the OPD-4000 is a powerful productivity tool reducing labor and material costs in quality assurance testing, industrial process controls or service and repair operations.

The OPD-4000 has no commercial equivalent as a general-purpose interferometric phase measurement instrument. With the user-friendly PhaseView™ software and indicators for input signals and modulation levels, the user is free to perform the task of taking critical measurements.

## COMPATIBLE WITH WIDE RANGE OF INTERFEROMETRIC CONFIGURATIONS

### Applicable Modulation Modes (internal and external)

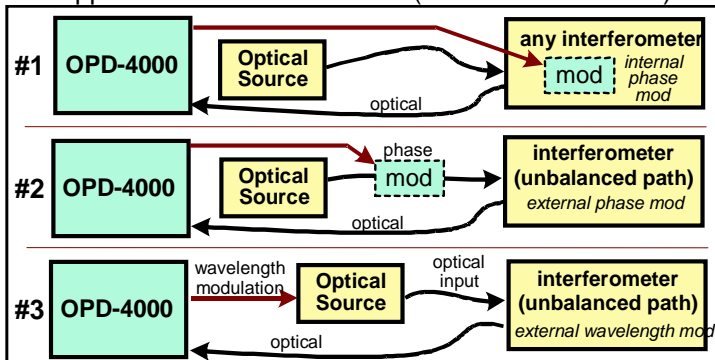

#1 uses an internal phase modulator (in one leg of any two beam interferometer or entry end of a Sagnac); #2 uses a phase modulator in-line to a mismatch path interferometer; #3 uses source wavelength modulation into mismatch path interferometer.

### Example: Fiber Mach-Zehnder

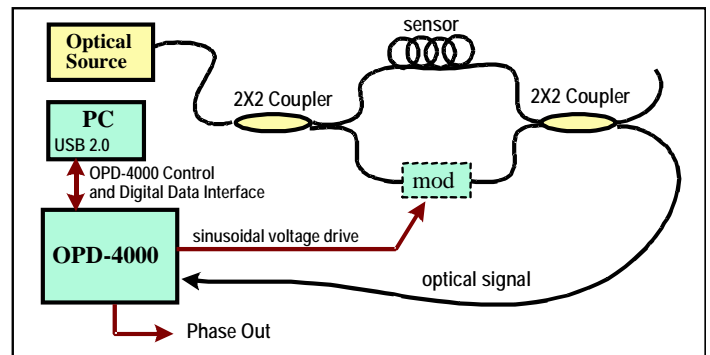

Example of OPD-4000 configured with a Mach-Zehnder interferometer with an internal phase modulator.

## FOR USE WITH

Bulk Interferometers	Fiber Interferometers
• General phase measurement	• Mach-Zehnder
• Polarimeters	• Michelson
• Projection or shearing interferometers	• Sagnac
	• Others

## APPLICATIONS

Large Structure	Environment	Industrial	Fiber Optic Instrumentation
• Structural Monitoring	• Oil & Gas Exploration	• Photonic Source Characterization	• Pressure
• Strain	• Wind Shear Detection	• HDD Metrology	• Temperature
• Accoustic	• Seismic	• Flow	• Acceleration
	• Thermal Dynamics	• Vibrometry	• Vibration
		• Profilometry	• Displacement
		• Velocimetry	• Acoustic

## SPECIFICATIONS

### MODULATOR DRIVE INTERFACE

Modulation Frequency	1 KHz to 70 KHz
Frequency Tuning	1 Hz resolution
Maximum Amplitude	13.8 V p-p 500 Ω load
Output Adjustment Range	1% to 100%
Connector	BNC

### OPTICAL INTERFACE

Wavelength	900 to 1700 nm
Programmable Gain Adjust [for proper ADC fill]	0 - 34 db
Max / Min Optical Power [to Input]	50 μW / 500 nW default
OPD-440	150 μW / 1.5 μW nominal
OPD-440P	600 μW / 6 μW nominal

### Receiver

OPD-440	InGaAs PIN / TIA @ 15 KV/W @ 1.5 μm
OPD-440P [PDR, each of three receivers]	InGaAs PIN / TIA @ 15 KV/W @ 1.5 μm

Note: OPD-440P has nominally 6.5 dB loss each receiver

Optical Connector	FC/APC wide key [assumes single mode type fibers]
-------------------	---

### OUTPUT

Analog Output	20 bit DAC
Full Scale Amplitude	[4π] V p-p behind 50 Ω [12.56 V p-p]
Resolution	20 bit
Data Averaging	1 to 65535
Scaling Range	0.5 - 32768 radians / volt, user selectable
High Pass Filter	0.1Hz – 3KHz
Digital Output	± 12,861 with 6 μ radians
Maximum Output rate	At modulation frequency
Data Averaging	1 to 65535
High Pass Filter	0.24 – 15923 Hz @ 50 KHz

### DEMULATION CHARACTERISTICS

Resolution	6 μ radians
Range	25,000 radians, ±12,861 radians
Self Noise	3 μrad/rt-Hz
Distortion	< 0.2% typical
Maximum Slew Rate	π times modulation frequency [Nyquist]
Internal Calculation	64 bits

### GENERAL

Power Universal	85-265 VAC, 47-440 Hz
Dimensions & Weight	6¼" H x 13" W x 20" D; 20 lbs.

### PC HOST REQUIREMENTS

CPU	≥ 500 MHz Pentium class
Interface	USB 2.0
Memory [RAM]	256MB minimum
Operating System	Windows 2000/NT/XP

### STANDARD SYSTEM CONFIGURATION

Single-channel Instrument	1 [OPD-440] receiver card; USB I/O [OPD-430] up to 8 receiver channels per chassis
---------------------------	--

### OPTIONS

Receiver Cards	1 card per receiver channel
OPD-440	Standard single element InGaAs receiver card
OPD-440P-13	Polarization Diversity Receiver card 1.3 μm
OPD-440P-15	Polarization Diversity Receiver card 1.5 μm

Note: Polarization Diversity Receivers are for interferometers with polarization fading.

Receiver Trans-impedance	User specified, from 10 to 100 KV/W
--------------------------	-------------------------------------

**This instrument requires a PC to operate.**

All trademarks and registrations are copyrights of their respective suppliers.

## PhaseView Main Screen



## Single-channel OPD-4000



The OPD-4000 is easy to set-up and use with a Windows host PC. The standard USB interface and the PhaseView application enable you to set-up, control and monitor digital output quickly and precisely.

## PhaseView Set-up Screen

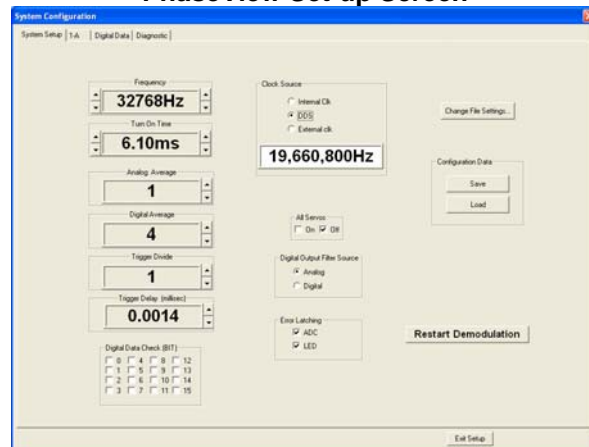

## Instrument Models

OPD-4000-20	Single channel; USB I/O, photodiode, 8 channel max
OPD-4000-20P	Single channel; USB I/O, 1.5um PDR, 8 channel max
OPD-4000-21P	Single channel; USB I/O, 1.3um PDR, 8 channel max